

ABB INDUSTRIAL DRIVES

ACS880-01

Quick installation and start-up guide

This guide is applicable to the global IEC and NEC North American installations.

Documentation in other languages

Ecodesign information
(EU 2019/1781 and SI 2021 No. 745)

About this document



3AXD50000754618 Rev E EN
2025-01-02
© 2025 ABB. All rights reserved.
Original instructions.



3AXD50000754618E

Safety instructions



WARNING! Obey these instructions. If you ignore them, injury or death, or damage to the equipment can occur. If you are not a qualified electrical professional, do not do electrical installation or maintenance work.



WARNING! If you activate the automatic fault reset or automatic restart functions of the drive control program, make sure that no dangerous situations can occur. These functions reset the drive automatically and continue operation after a fault or supply break. If these functions are activated, the installation must be clearly marked as defined in IEC/EN 61800-5-1, subclause 6.5.3, for example, "THIS MACHINE STARTS AUTOMATICALLY".

- Do not do work on the drive, motor cable, motor, or control cables when the drive is connected to the input power. Before you start the work, isolate the drive from all dangerous voltage sources and measure that there are no dangerous voltages. Always wait for 5 minutes after disconnecting the input power to let the intermediate circuit capacitors discharge.
- Do not do work on the drive when a rotating permanent magnet motor is connected to it. A rotating permanent magnet motor energizes the drive, including its input and output terminals.
- Make sure that debris from drilling, cutting and grinding, does not enter the drive.
- **Frames R4...R9:** Use the lifting eyes of the drive when you lift the drive. Do not tilt the drive. The drive is heavy and its center of gravity is high. An overturning drive can cause physical injury.

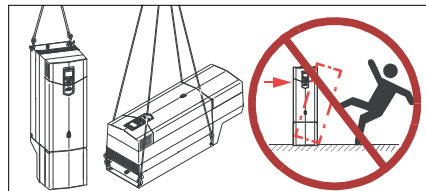

1. Unpack the drive

Keep the drive in its package until you are ready to install it. After unpacking, protect the drive from dust, debris and moisture. Make sure that these items are included: cable/conduit box (frames R5...R9 of IP21 [UL Type 1]), drive, mounting template, control panel, quick installation and start-up guide, multilingual residual voltage warning stickers, hardware and firmware manuals (if ordered), options in separate packages (if ordered). Make sure that there are no signs of damage to the items.

2. Reform the capacitors

If the drive has not been powered up for a year or more, you must reform the DC link capacitors. See [Related documents](#) or contact ABB technical support.

3. Select the cables and fuses

- Select the power cables. Obey the local regulations.
 - **Input power cable:** Use symmetrical shielded cable (VFD cable) for the best EMC performance. **NEC installations:** Conduit with continuous conductivity is also allowed and must be grounded on both ends.
 - **Motor cable:** ABB recommends symmetrically shielded VFD motor cable to reduce bearing current and wear and stress on motor insulation and to provide the best EMC performance. Although not recommended, conductors inside continuously conductive conduit is allowed in NEC installations. Ground conduit on both ends.
 - **Power cable types:** **IEC installations:** Use copper cables. Aluminum cables can only be used with frame sizes R5...R9. **NEC installations:** Only copper conductors are allowed.
 - **Current rating:** max. load current.
 - **Voltage rating (minimum):** **IEC installations:** 600 V AC cable is accepted for up to 500 V AC, 750 VAC cable is accepted for up to 600 V AC, 1000 V AC cable is accepted for up to 690 V AC. **NEC installations:** 600 V AC for 230 V AC

motors and 1000 V AC for 480 V AC and 600 V AC motors. 600 V AC for 230 V AC and 480 V AC power lines; 1000 V AC for 600 V AC power line.

- **Temperature rating:** IEC installations: Select a cable rated for at least 70 °C maximum permissible temperature of conductor in continuous use. NEC installations: Use 75 °C conductors minimum. Insulation temperature can be higher as long as the ampacity is based on 75 °C conductors.
- Select the control cables.
 - Use double-shielded twisted-pair cable for analog signals. Use double-shielded or single-shielded cable for the digital, relay and I/O signals. Do not run 24 V and 115/230 V signals in the same cable.
- Protect the drive and input power cable with the correct fuses. See [Ratings, fuses and typical power cables](#).

4. Examine the installation site

Examine the drive installation site. Make sure that:

- The installation site is sufficiently ventilated or cooled to remove heat from the drive.
- The ambient conditions of the drive meet the specifications. See [Ambient conditions](#).
- The wall behind the drive and the material above and below the unit is of non-flammable material.
- The installation surface is as close to vertical as possible and strong enough to support the drive.
- There is sufficient free space around the drive for cooling, maintenance and operation. For the minimum free space requirements, refer to [Dimensions, weights and free space requirements](#).
- There are no sources of strong magnetic fields such as high-current single-core conductors or contactor coils near the drive. A strong magnetic field can cause interference or inaccuracy in the operation of the drive.

5. Install the drive on the wall

Select fasteners that comply with local requirements applicable to wall surface materials, drive weight and application.

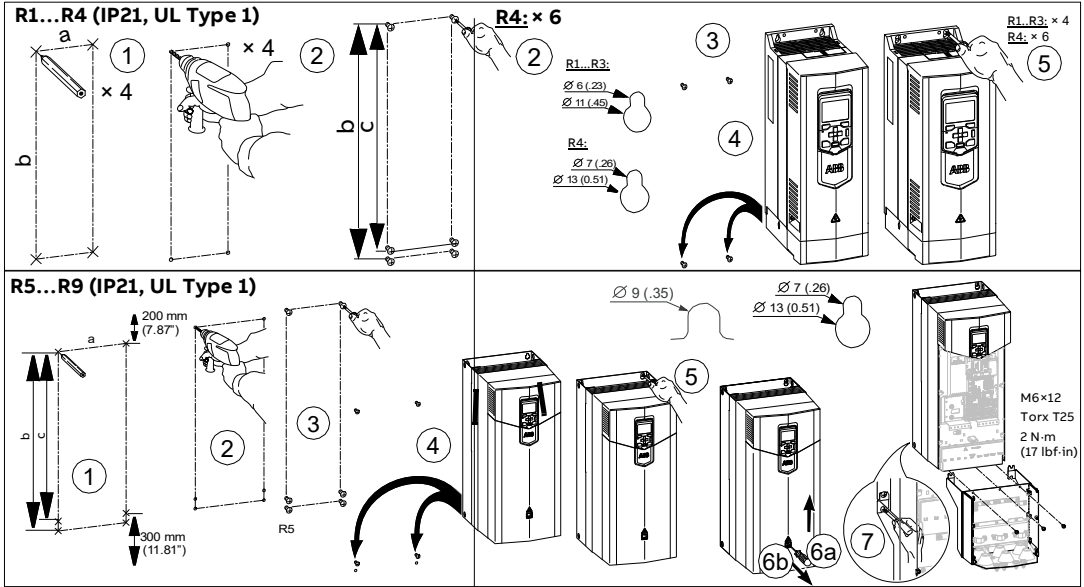

	R1		R2		R3		R4		R5		R6		R7		R8		R9	
	mm	in	mm	in	mm	in	mm	in	mm	in	mm	in	mm	in	mm	in	mm	in
a	98	3.85	98	3.85	125	4.92	160	6.30	160	6.30	212.5	8.37	245	9.65	262.5	10.33	345	13.58
b	358	14.09	358	14.09	451	17.75	505	19.88	612	24.10	571	22.50	623	24.53	701	27.61	718	28.29
c	-	-	-	-	-	-	475	18.70	581	22.87	531	20.91	583	22.95	658	25.91	658	25.91

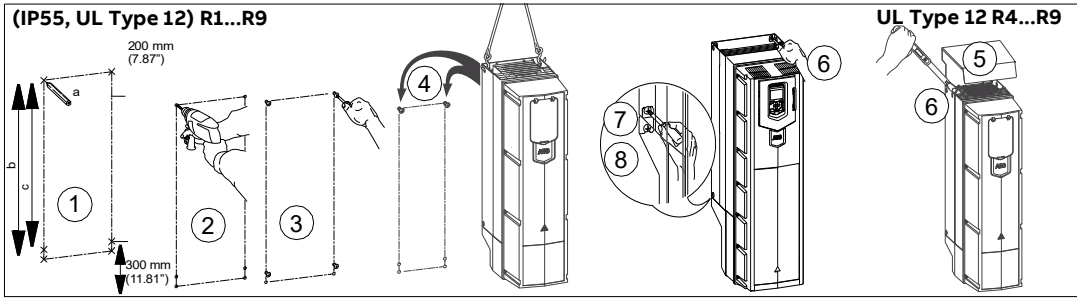

6. Remove the covers.

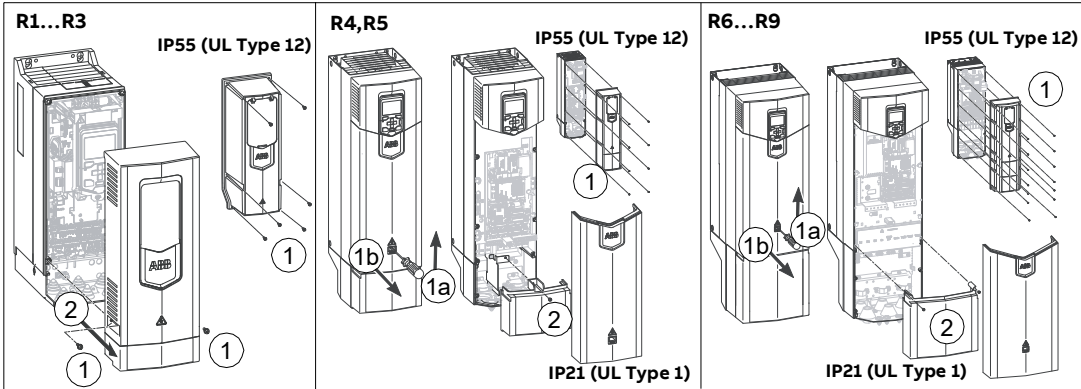

7. Make sure that the drive is compatible with the grounding system

You can connect all drives to a symmetrically grounded TN-S system (center-grounded wye). **With option +E200 or +E202:** If you install the drive to a different system, you must remove the EMC screw (disconnect the EMC filter) and/or remove the VAR screw (disconnect the varistor circuit).

Frame	Symmetrically grounded TN-S systems (center-grounded wye)	Corner-grounded delta and midpoint-grounded delta systems	IT systems (ungrounded or high-resistance grounded)	TT systems ¹⁾²⁾
R1...R4	Do not remove EMC AC or VAR screws.	Do not remove EMC AC or VAR screws.	Remove EMC AC, EMC DC and VAR screws.	Remove EMC AC, EMC DC and VAR screws.
R5...R9		Do not remove EMC AC or VAR screws. Remove EMC DC screw.	Remove EMC AC, EMC DC and VAR screws.	Remove EMC AC, EMC DC and VAR screws.

1) A residual current device must be installed in the supply system. In NEC installations the residual current device is only required at or above 1000 amps.

2) ABB does not guarantee the EMC category or the operation of the ground leakage detector built inside the drive.



WARNING! Do not install the drive on a 525...690 V corner-grounded or midpoint-grounded delta system. Disconnecting the EMC filter and ground-to-phase varistor does not prevent damage to the drive.

8. Measure the insulation resistance of the power cables and the motor

Measure the insulation resistance of the input cable before you connect it to the drive. Obey local regulations.

Measure the insulation resistance of the motor cable and motor when the cable is disconnected from the drive. Measure the insulation resistance between each phase conductor and the PE conductor. Use a measuring voltage of 1000 V DC. The insulation resistance of an ABB motor must be more than 100 Mohm (reference value at 25 °C). For the insulation resistance of other motors, see the manufacturer's instructions. Moisture inside the motor decreases the insulation resistance. If you think that there is moisture, dry the motor and do the measurement again.

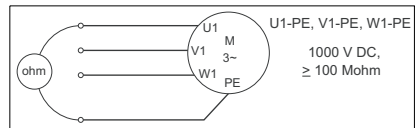

9. Connect the power cables

IEC connection diagram with shielded cables

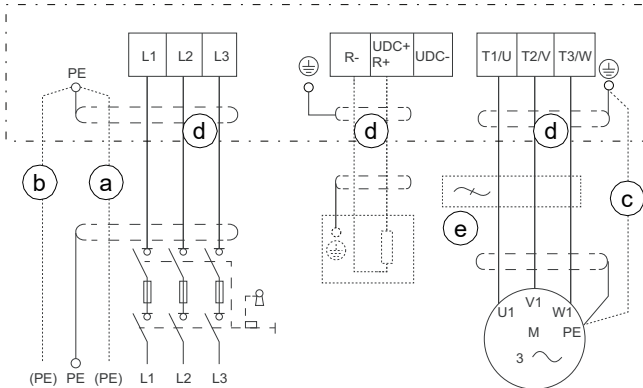

- a. Two protective earth (ground) conductors. Drive safety standard IEC/EN 61800-5-1 requires two PE conductors, if the cross-sectional area of the PE conductor is less than 10 mm² Cu or 16 mm² Al. For example, you can use the cable shield in addition to the fourth conductor.

- b. Use a separate grounding cable or a cable with a separate PE conductor for the line side, if the conductivity of the fourth conductor or shield does not meet the requirements for the PE conductor.
- c. Use a separate grounding cable for the motor side, if the conductivity of the shield is not sufficient, or if there is no symmetrically constructed PE conductor in the cable.
- d. 360° grounding of the cable shield is required for the motor cable and brake resistor cable (if used). It is also recommended for the input power cable.
- e. If necessary, install an external filter (du/dt, common mode, or sine filter). Filters are available from ABB.

Frames R1...R4 have a built-in brake chopper as standard. Frames R5 and up can be equipped with optional built-in brake chopper (+D150). Brake resistors are available as add-on kits.

NEC connection diagram with symmetrically shielded cable or conduit

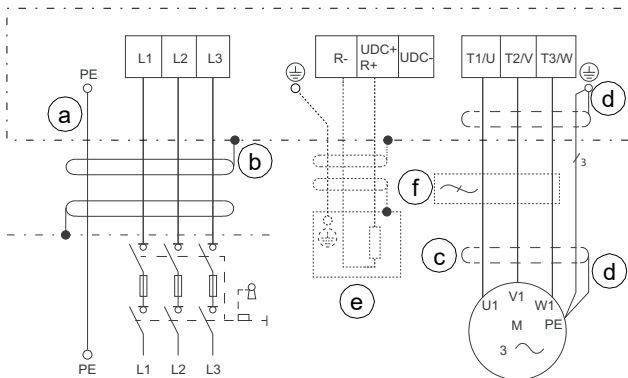

Note: NEC installation can include separate insulated conductors inside a conduit, shielded VFD cable in conduit, or shielded VFD cable without conduit. The normal dashed symbol (c) in this diagram represents the shield of shielded VFD cable. The same solid symbol (b) represents conduit.

- a. Insulated ground conductor in a conduit: Ground to drive's PE terminal and to the distribution panel ground bus. For a VFD cable installation see d.
- b. Conduit ground: Bond the conduit to the drive's conduit box and to the distribution panel enclosure. For a VFD cable installation see c.

- c. Shield of a VFD shielded cable: Ground the shield 360° under drive's grounding clamp, then twist with the ground conductors and connect under the drive's ground terminal. Ground the shield also 360° at the motor end, then twist and connect under the motor's ground terminal. For a conduit installation see b.
- d. Symmetrically constructed grounding conductors inside a VFD shielded cable: Twist together, combine with the shield and connect under the drive's ground terminal and under the motor's ground terminal. For a conduit installation see a.
- e. External brake resistor connection (if used): For a conduit installation see a and b. For a VFD cable installation see c and d. In addition, cut the third phase conductor which is not needed for the brake resistor connection.
- f. If necessary, install an external filter (du/dt, common mode, or sine filter). Filters are available from ABB.

Frames R1...R4 have a built-in brake chopper as standard. Frames R5 and up can be equipped with optional built-in brake chopper (+D150). Brake resistors are available as add-on kits.

Note: All openings in the drive enclosure must be closed with UL listed devices having the same Type rating as the drive Type.

Connection procedure with VFD cable

For connection procedure with conduits, see [Connection procedure with conduit](#).

Attach a residual voltage warning sticker in the local language:

Frames R1...R3: to the control panel mounting platform

Frames R4, R5: next to the control unit top

Frames R6...R9: next to the L3 conductor.

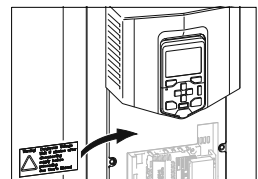
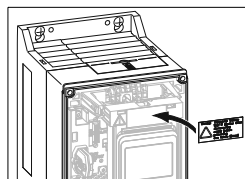

- Frames R5...R9:** Remove the shroud on the power cable terminals (1a), then make the necessary holes for the cables (1b).

Frames R6...R9: Remove the side plates (1a). Remove the shroud (1b), then make the necessary holes for the cables (in R8...R9, also do this for the lower shroud).

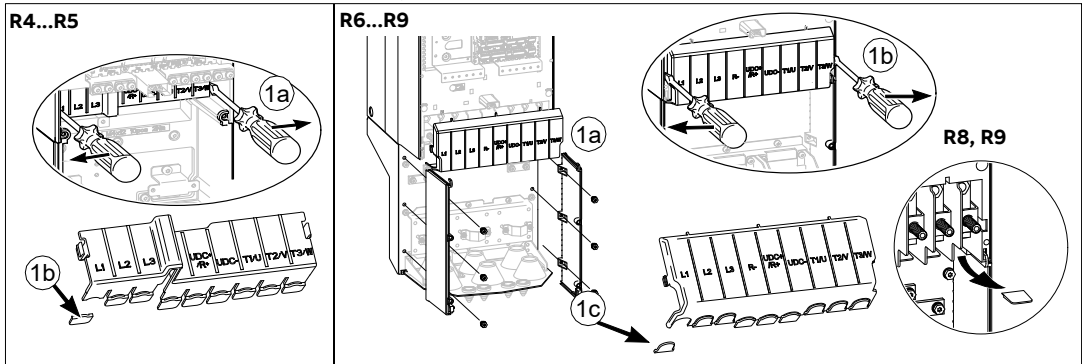

- Prepare the power cables:

 - Remove the rubber grommets from the cable entry.
 - Frames R1...R3, IP21:** Attach the Romex clamps (included in the delivery in a plastic bag) to the cable entry plate holes (2a).
 - Frames R1...R9 IP55:** Cut a sufficient hole in the rubber grommet. Slide the grommet onto the cable (2b).
 - Prepare the ends of the input power cable and motor cable as illustrated in the applicable figure (2c).
 - Frames R4...R9 IP21 and frames R1...R9 IP55:** Slide the cables through the holes in the cable entry and attach the grommets to the holes.

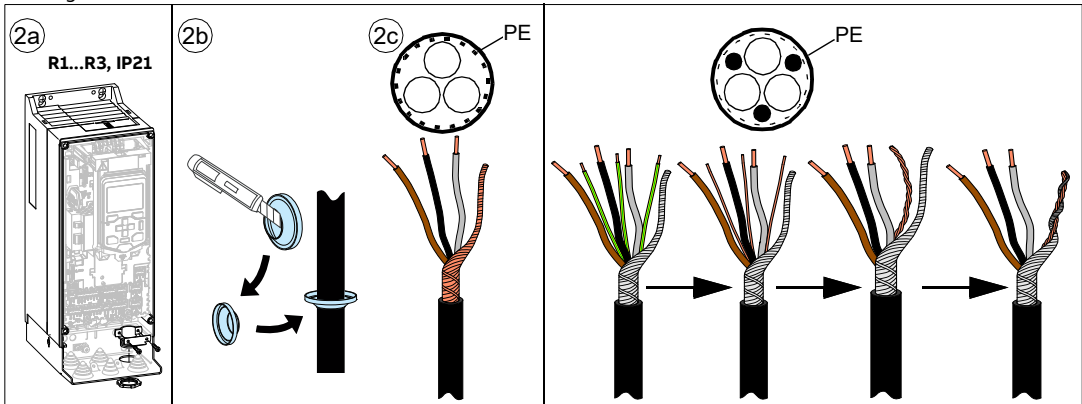

- Connect the power cables. For the tightening torques, refer to [Terminal data](#).

 - For frames R1...R3:** Ground the cable shields 360° in the Romex clamp (IP21/Type 1 units). For IP55 (Type 12) ground the cable shield 360° on grounding shelf as shown in R4...R5 (a). R1...R3 grounding shelf is not shown for IP55/Type 12 drive.
 - For frames R4...R9:** Tighten the clamps of the power cable grounding shelf onto the stripped part of the cables (a).
 - Connect the twisted shield of the cable shields to the grounding terminals (b).
 - Frames R6...R9:** To install the common mode filter, see [Related documents](#).
 - Connect the phase conductors of the motor cable to the T1/U, T2/V and T3/W terminals. Connect the input power cable to the L1, L2 and L3 terminals (c). Connect the brake resistor cables to R+ and R- terminals if brake chopper is in use (d).
 - Frames R6...R9:** After you have connected the power cables, install the shroud on the terminals.

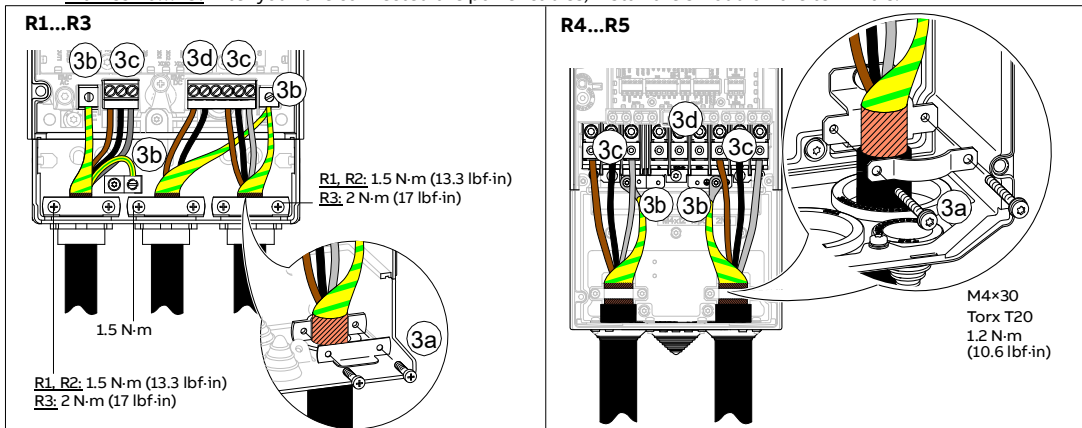

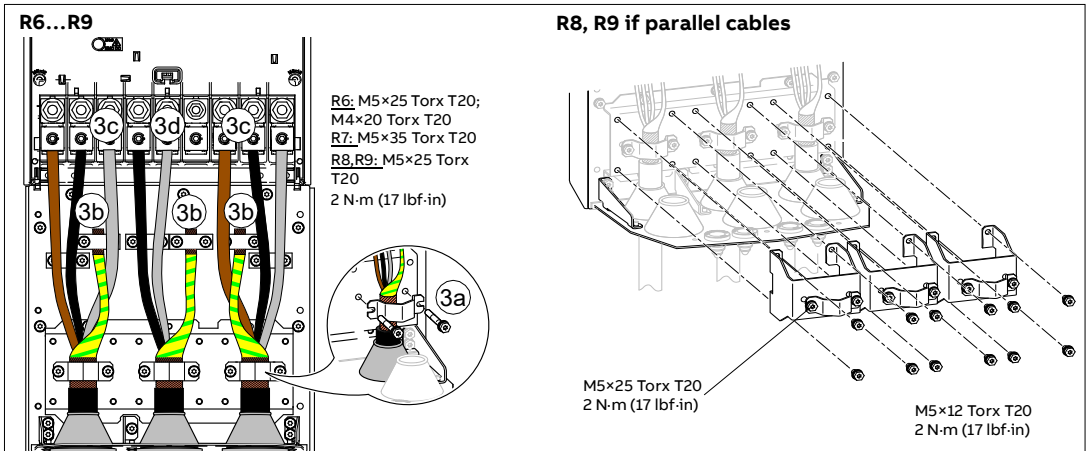

4. Frames R1...R3 and R6...R9: Install the control cable grounding shelf.

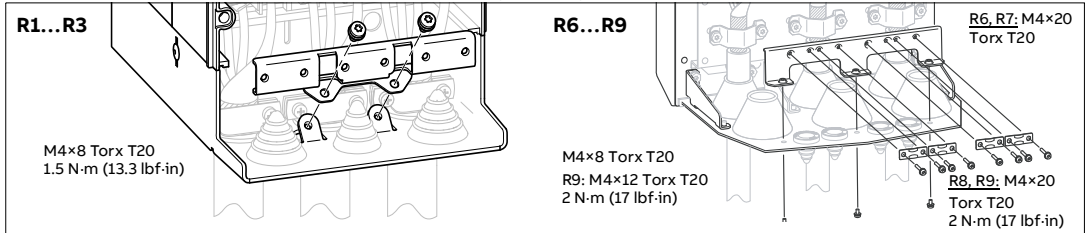

Frames R4, R5: Install the EMC shroud (a). Frames R4...R9: Install the shroud (b).

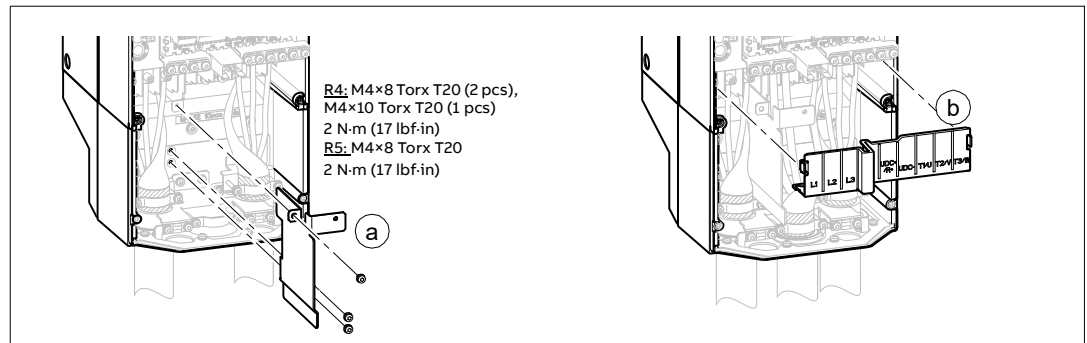

5. In frames R6...R9, install the side plates if removed. Attach the cables outside the drive mechanically.

6. Ground the motor cable shield at the motor end. For minimum radio frequency interference, ground the motor cable shield 360° at the cable entry of the motor terminal box.

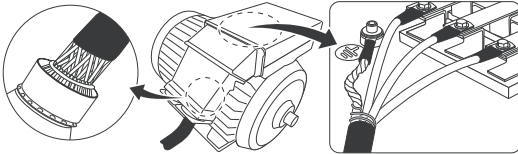

10. Connect the control cables

Make the connections according to the application. Keep the signal wire pairs twisted as near to the terminals as possible to prevent inductive coupling.

1. Cut a hole into the rubber grommet and slide the grommet onto the cable.
2. Ground the outer shield of the cable 360° under the grounding clamp. Keep the cable unstripped as close to the terminals of the control unit as possible. Frames R1...R3: Ground also the pair-cable shields and grounding wires at the cable entry box grounding clamp. Frames R4...R9: Ground the pair-cable shields and all grounding wires to the clamp below the control unit.
3. Tie all control cables to the provided cable tie mounts.

Default I/O connections

Wire sizes:
0.5 ... 2.5 mm²
(24...12 AWG)
Tightening
torques: 0.5 N·m
(5 lbf·in) for both
stranded and
solid wiring.

XPOW External power input		
1	+24VI	24 V DC, 2 A
2	GND	
XAI Reference voltage and analog inputs		
1	+VREF	11 V DC, R_i 1...10 kohm
2	-VREF	-11 V DC, R_i 1...10 kohm
3	AGND	Ground
4	AI1+	Speed reference 0(2)...11 V, $R_{in} >$ 200 kohm
5	AI1-	
6	AI2+	By default not in use. 0(4)...22 mA, $R_{in} =$ 100 ohm
7	AI2-	
J1	J1	AI1 current/voltage selection jumper
J2	J2	AI2 current/voltage selection jumper
XAO Analog outputs		
1	AO1	Motor speed rpm 0...22 mA, $R_L <$ 500 ohm
2	AGND	
3	AO2	Motor current 0...22 mA, $R_L <$ 500 ohm
4	AGND	
XD2D Drive-to-drive link		
1	B	Drive-to-drive link
2	A	
3	BGND	
J3	J3	Drive-to-drive link termination switch
XRO1, XRO2, XRO3 Relay outputs		
11	NC	Ready 250 V AC / 30 V DC 2 A
12	COM	
13	NO	
21	NC	Running 250 V AC / 30 V DC 2 A
22	COM	
23	NO	
31	NC	Faulted(-1) 250 V AC / 30 V DC 2 A
32	COM	
33	NO	
XD24 Digital interlock		
1	DIIL	Run enable
2	+24VD	+24 V DC 200 mA ¹⁾
3	DICOM	Digital input ground
4	+24VD	+24 V DC 200 mA ¹⁾
5	DIOGND	Digital input/output ground
J6		Ground selection switch
XDIO Digital input/outputs		
1	DIO1	Output: Ready
2	DIO2	Output: Running
XDI Digital inputs		
1	DI1	Stop (0) / Start (1)
2	DI2	Forward (0) / Reverse (1)
3	DI3	Reset
4	DI4	Acceleration & deceleration select
5	DI5	Constant speed 1 (1 = On)
6	DI6	By default not in use.
XSTO Safe torque off		
1	OUT1	Safe torque off. Both circuits must be closed for the drive to start.
2	SGND	
3	IN1	
4	IN2	
X12	Safety functions module connection	
X13	Control panel connection	
X205	Memory unit connection	

¹⁾ Total load capacity of these outputs is 4.8 W (200 mA / 24 V) minus the power taken by DIO1 and DIO2.

Control cable installation examples

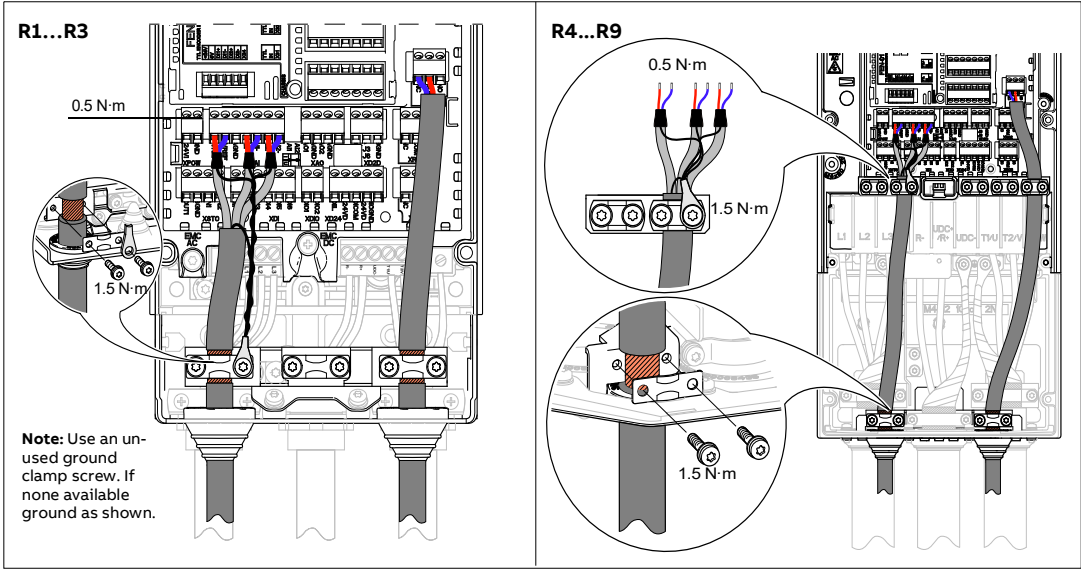

11. Install optional modules, if included in the delivery

Fieldbus cabling example

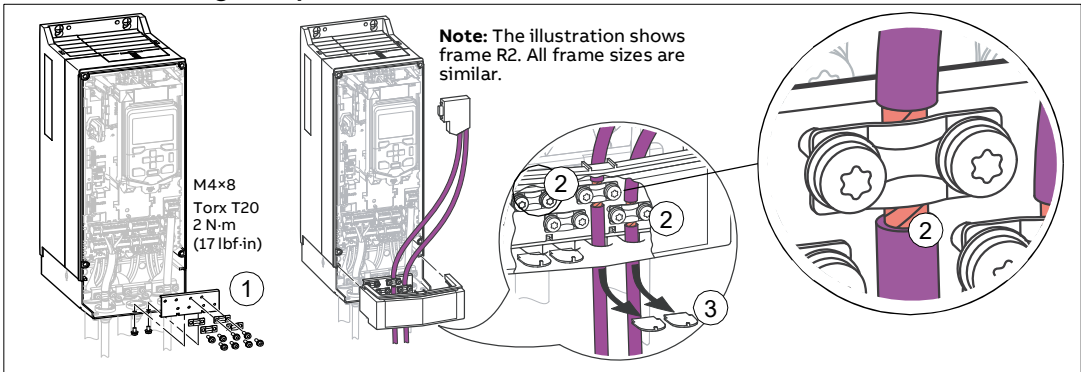

12. Install the cover(s)

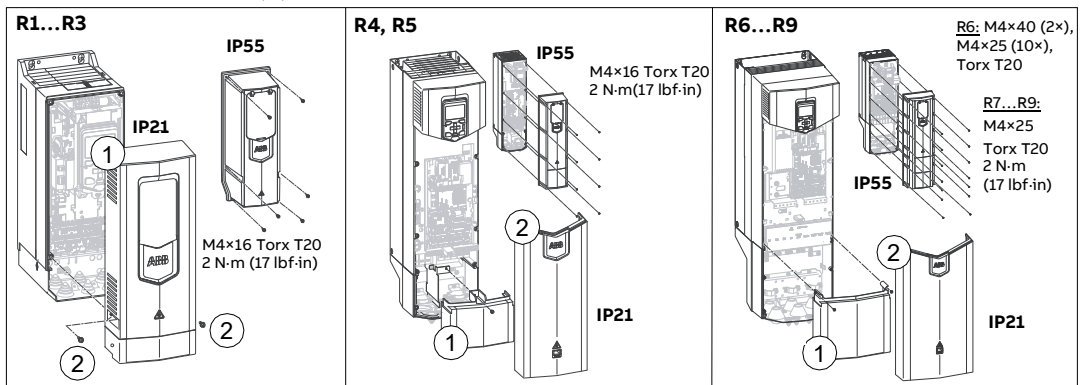

Connection procedure with conduit



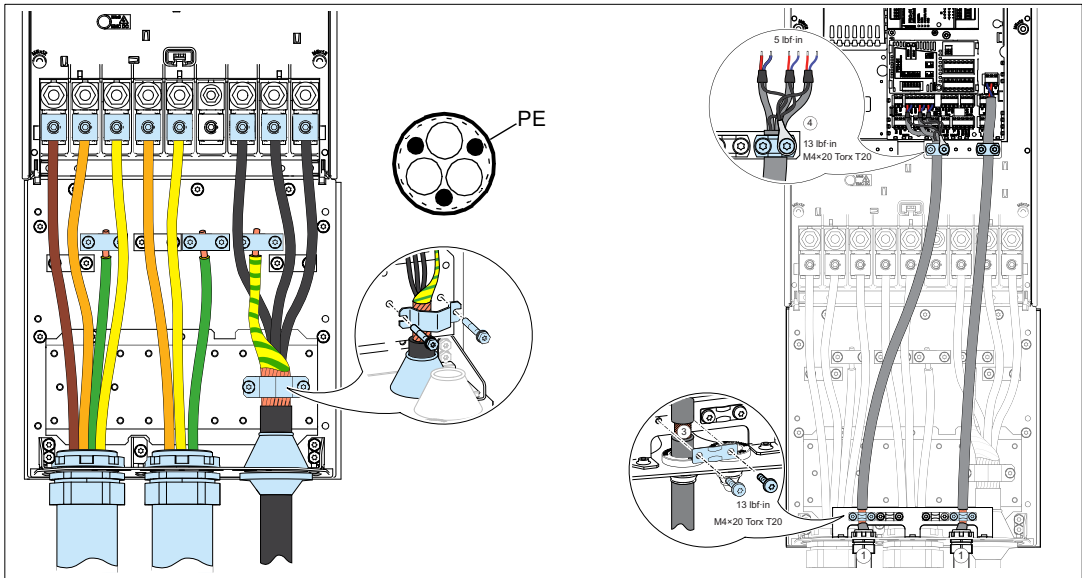



1. Connect the power cables. ABB recommends symmetrically shielded VFD cable for connecting the motor.
 - Attach the residual voltage warning sticker and remove the covers as instructed in [Connection procedure with VFD cable](#).
 - Remove the rubber grommets from the conduit plate for the conduit to be connected.
 - Attach the conduit to the drive conduit plate, and to the motor or source of power distribution. Make sure conduit is correctly bonded at both ends of the conduit. Ensure conductivity of the conduit. Slide the VFD shielded cable or discrete conductors through the conduit and strip the cable ends.
 - If you use a symmetrically shielded VFD cable, twist the grounding wires together with the cable shield and connect them to the grounding terminals. Ground the shield 360° at the grounding clamp. If you use discrete conductors connect the insulated ground conductor to the ground terminal.
 - Connect the input and motor conductors and tighten cable terminals. For the tightening torques, refer to [Terminal data](#).
 - **Frames R4, R5:** Install the EMC shroud separating the input and output cabling if not installed yet.
 - **If brake chopper is in use:** Connect the brake resistor conductors to the R+ and R- terminals.
 - Reinstall the shroud on the power cable terminals.
2. Connect the control cables
 - Attach the cable conduits to the drive conduit plate. Make sure conduit is correctly bonded at both ends and that the conductivity is consistent throughout the conduit. Slide the control cables through the conduit.
 - Cut to suitable length (note the extra length of the grounding conductors) and strip the conductors.
 - Ground the outer shields of all control cables 360° at a grounding clamp.
 - Ground the pair-cable shields to the grounding clamp. Use an unused ground clamp screw. If none available ground as shown. Leave the other end of the shields unconnected or ground them indirectly via a high-frequency capacitor with a few nanofarads, eg. 3.3 nF / 630 V.
 - Connect the conductors to the appropriate terminals of the control unit.
 - Wire the optional modules if included in the delivery.
 - Reinstall the front covers as instructed in [Install the cover\(s\)](#).













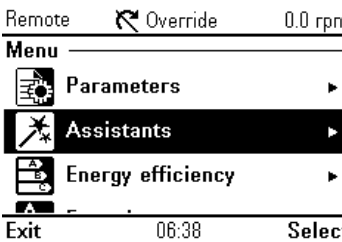

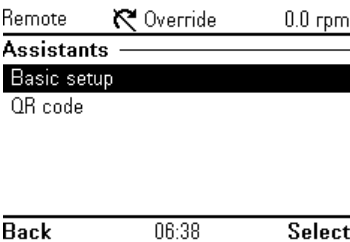

13. Start-up the drive

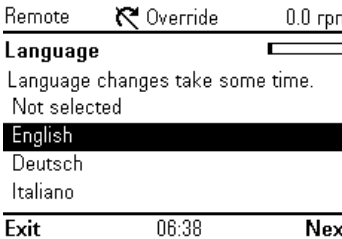
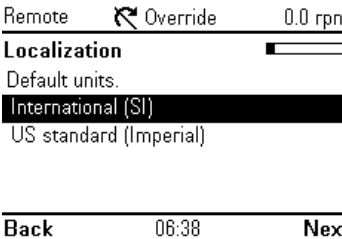
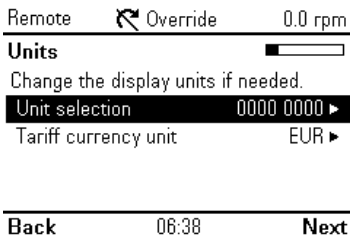
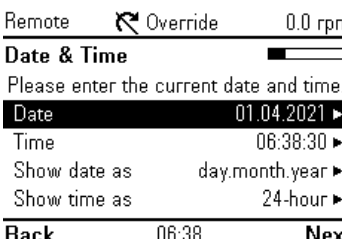
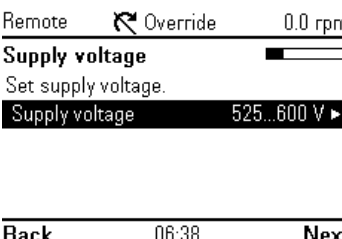
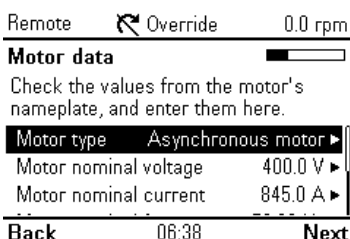
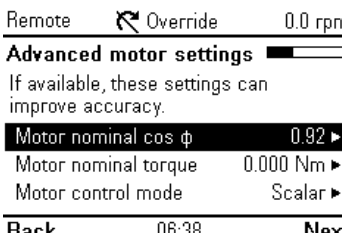
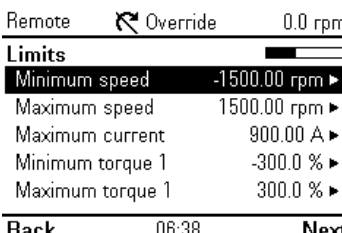
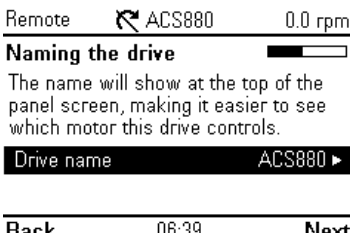

WARNING! Obey these instructions. If you ignore them, injury or death, or damage to the equipment can occur. If you are not a qualified electrical professional, do not do electrical installation or maintenance work.

Use the control panel to do the start-up procedure. The two commands at the bottom of the display show the functions of the two softkeys  and  located below the display. The commands assigned to the softkeys are different depending on the context. Use the arrow keys , ,  and  to move the cursor or change values depending on the active view. Key  shows a context-sensitive help page.

<p>1. Power up the drive. Make sure that you have the motor name plate data available.</p>	<p>2. The First start assistant guides you through the first start-up. Select Menu and press  (Menu) to open the main Menu. Select Assistants and press  (Select).</p> 	<p>3. Select Basic setup and press  (Select).</p> 
<p>4. Select the language you want to use and press  (Next). Note: After you have selected the language, it takes a few minutes for the control panel to wake up.</p>	<p>5. Select the localization you want to use and press  (Next).</p>	<p>6. Do the following selections. After each, press  (Next).</p>
		
<p>7.</p> 	<p>8.</p> 	<p>9.</p> 
<p>10.</p> 	<p>11.</p> 	<p>12.</p> 

13.	14.	
Remote  ACS880 0.0 rpm Direction test  Spin the motor to check direction. No, skip the test Yes, test now	Remote  ACS880 0.0 rpm Make backup?  Copies all settings into a backup file stored in the control panel. To restore a backup, go to Menu > Backups. Not now Backup	Remote  ACS880 0.0 rpm Set-up complete Drive is ready for use.
Back 06:39 Next	Back 06:41 Next	Back 06:41 Done

Motor overload protection

The factory motor overload protection is not enabled by default. Motor thermal overload protection can be measured using motor temperature devices, can be estimated using a motor model defined by parameters, or can use measured motor current and motor Class curves. To enable protection using motor model parameters or measurement devices set parameter 35.11 and subsequent parameters through 35.55. To enable motor Class curves set parameter 35.56. Motor overload Class is defaulted to 20 and selectable in parameter 35.57.

Use the information key (i) on the drive control panel for more information on setting group 35 parameters. You must set the drive overload parameters correctly, or motor damage could occur.

Fieldbus communication

To configure the embedded fieldbus communication for Modbus RTU, you must set at least these parameters:

Parameter	Setting	Description
20.01 Ext1 commands	Embedded fieldbus	Selects fieldbus as the source for the start and stop commands when EXT1 is selected as the active control location.
22.11 Speed ref1 source	EFB ref1	Selects a reference received through the embedded fieldbus interface as speed reference 1.
26.11 Torque ref1 source	EFB ref1	Selects a reference received through the embedded fieldbus interface as torque reference 1.
28.11 Frequency ref1 source	EFB ref1	Selects a reference received through the embedded fieldbus interface as frequency reference 1.
58.01 Protocol enable	Modbus RTU	Initializes embedded fieldbus communication.
58.03 Node address	1 (default)	Node address. There must be no two nodes with the same node address on-line.
58.04 Baud rate	19.2 kbps (default)	Defines the communication speed of the link. Use the same setting as in the master station.
58.05 Parity	8 EVEN 1 (default)	Selects the parity and stop bit setting. Use the same setting as in the master station.
58.06 Communication control	Refresh settings	Validates any changed EFB configuration settings. Use this after changing any parameters in group 58.

Other parameters related to the fieldbus configuration:

58.14 Communication loss action	58.17 Transmit delay	58.28 EFB act1 type	58.34 Word order
58.15 Communication loss mode	58.25 Control profile	58.31 EFB act1 transparent source	58.101 Data I/O 1 ...
58.16 Communication loss time	58.26 EFB ref1 type	58.33 Addressing mode	58.124 Data I/O 24

Warnings and faults

Warning	Fault	Aux. code	Description
A2A1	2281	Current calibration	Warning: Current calibration is done at the next start. Fault: Output phase current measurement fault.
-	2310	Overcurrent	The output current is more than the internal limit. This can also be caused by an earth fault or phase loss.
A2B3	2330	Earth leakage	A load unbalance that is typically caused by an earth fault in the motor or the motor cable.
A2B4	2340	Short circuit	There is a short-circuit in the motor or the motor cable.
-	3130	Input phase loss	The intermediate DC circuit voltage oscillates due to missing input power line phase.
-	3181	Wiring or earth fault	Incorrect input and motor cable connection.
A3A1	3210	DC link overvoltage	Intermediate DC circuit voltage is too high.
A3A2	3220	DC link undervoltage	Intermediate DC circuit voltage is too low.
-	3381	Output phase loss	All three phases are not connected to the motor.
-	5090	STO hardware failure	STO hardware diagnostics has detected hardware failure. Contact ABB.
A5A0	5091	Safe torque off	The Safe torque off (STO) function is active.
A7CE	6681	EFB comm loss	Break in embedded fieldbus communication.
A7C1	7510	FBA A communication	Communication lost between drive (or PLC) and fieldbus adapter.
A7AB	-	Extension I/O configuration failure	The I/O extension module types and locations specified by parameters do not match the detected configuration.
AFF6	-	Identification run	The motor ID run occurs at the next start.

Warning	Fault	Aux. code	Description
-	FA81	Safe torque off 1 loss	The Safe torque off circuit 1 is broken.
-	FA82	Safe torque off 2 loss	The Safe torque off circuit 2 is broken.

Ratings, fuses and typical power cables

1) Typical motor power with no overload capacity (nominal use). The kilowatt ratings apply to most IEC 4-pole motors. The horsepower ratings apply to most NEMA 4-pole motors.

2) For IEC installations, ABB recommends aR fuses. See hardware manual for guidelines in selecting between aR and gG fuses, and for additional fuse alternatives.

3) The recommended branch protection fuses must be used to maintain the IEC/EN/UL 61800-5-1 and CSA C22.2 No. 274 certifications. Refer to note 6 for circuit breaker protection.

4) **IEC 61439-1**: The drive is suitable for use on a circuit capable of delivering not more than 65 kA when protected by the fuses given in this table.

5) **UL 61800-5-1, CSA C22.2 No. 274**: The drive is suitable for use on a circuit capable of delivering not more than 100 kA symmetrical amperes (rms) at 600 V maximum when protected by the ABB recommended fuses.

6) Refer to **Alternate Fuses, MPPs and Circuit Breakers for ABB Drives (3AXD50000645015 [English])** for additional UL fuses and circuit breakers that can be used as branch circuit protection.

7) Class J, CC, and CF fuses are also allowed at the same nominal current and voltage ratings.

8) **IEC 61800-9-2**: Typical drive losses when it operates at 90% of the nominal output frequency and 100% of the nominal output current.

9) **IEC Installations**: The cable sizing is based on max. 9 cables laid on a cable ladder side by side, three ladder type trays one on top of the other, ambient temperature 30 °C, PVC insulation, surface temperature 70 °C (EN 60204-1 and IEC 60364-5-52/2001). For other conditions, size the cables according to local safety regulations, appropriate input voltage and the load current of the drive.

10) **NEC Installations**: The cable sizing is based on NEC Table 310-16 for copper wires, 75 °C (167 °F) wire insulation at 40 °C (104 °F) ambient temperature. Not more than three current-carrying conductors in raceway or cable or earth (directly buried). For other conditions, size the cables according to local safety regulations, appropriate input voltage and the load current of the drive.

ACS880 -01-...	Frame size	Nominal ratings IEC / UL (NEC)				Fuses ³⁾			Typical power cable		Typical power loss ⁸⁾
		Input current	Output current	Motor power ¹⁾		gG fuse ⁴⁾ (DIN 43620)	aR fuse ²⁾⁴⁾ (DIN 43653)	UL class T ⁵⁾⁶⁾⁷⁾	Copper		
				P_n	P_{Ld}				mm ² ⁹⁾	AWG/ kcmil ¹⁰⁾	
		I_L	I_2 / I_{Ld}	kW	hp	ABB type	Bussmann type				
$U_n = 3\text{-phase } 230\text{ V}$											
04A6-2	R1	4.6 / 4.4	4.6 / 4.4	0.75	1.0	OFAF000H6	170M1309	JJS-15	3×1.5	14	61
06A6-2	R1	6.6 / 6.3	6.6 / 6.3	1.1	1.5	OFAF000H10	170M1309	JJS-15	3×1.5	14	85
07A5-2	R1	7.5 / 7.1	7.5 / 7.1	1.5	2.0	OFAF000H16	170M1309	JJS-15	3×1.5	14	96
10A6-2	R1	10.6 / 10.1	10.6 / 10.1	2.2	3.0	OFAF000H16	170M1309	JJS-20	3×1.5	14	149
16A8-2	R2	16.8 / 16.0	16.8 / 16.0	4.0	5.0	OFAF000H25	170M1311	JJS-25	3×6	10	210
24A3-2	R2	24.3 / 23.1	24.3 / 23.1	5.5	7.5	OFAF000H40	170M1313	JJS-35	3×6	8	368
031A-2	R3	31.0 / 29.3	31.0 / 29.3	7.5	10	OFAF000H50	170M1315	JJS-50	3×10	8	354
046A-2	R4	46 / 44	46 / 44	11	15	OFAF000H63	170M1316	JJS-80	3×16	6	541
061A-2	R4	61 / 58	61 / 58	15	20	OFAF000H80	170M1318	JJS-80	3×25	4	804
075A-2	R5	75 / 71	75 / 71	18.5	25	OFAF000H100	170M3013	JJS-110	3×35	3	925
087A-2	R5	87 / 83	87 / 83	22	30	OFAF000H125	170M3014	JJS-110	3×35	2	1142
115A-2	R6	115 / 109	115 / 109	30	40	OFAF000H160	170M3015	JJS-150	3×50	1/0	1362
145A-2	R6	145 / 138	145 / 138	37	50	OFAF0H200	170M3016	JJS-200	3×95	3/0	1935
170A-2	R7	170 / 162	170 / 162	45	60	OFAF0H250	170M3017	JJS-250	3×120	4/0	1968
206A-2	R7	206 / 196	206 / 196	55	75	OFAF1H315	170M3018	JJS-300	3×150	300 MCM	2651
274A-2	R8	274 / 260	274 / 260	75	100	OFAF2H400	170M3019	JJS-400	2×(3×95)	2×2/0	3448
$U_n = 3\text{-phase } 400\text{ V}$											
02A4-3	R1	2.4	2.4	0.75	-	OFAF000H4	170M1311	JJS-15	3×1.5	14	43
03A3-3	R1	3.3	3.3	1.1	-	OFAF000H6	170M1311	JJS-15	3×1.5	14	52
04A0-3	R1	4.0	4.0	1.5	-	OFAF000H6	170M1311	JJS-15	3×1.5	14	59
05A6-3	R1	5.6	5.6	2.2	-	OFAF000H10	170M1311	JJS-15	3×1.5	14	78
07A2-3	R1	8.0	8.0	3.0	-	OFAF000H10	170M1311	JJS-15	3×1.5	14	112
09A4-3	R1	10.0	10.0	4.0	-	OFAF000H16	170M1311	JJS-15	3×1.5	14	146
12A6-3	R1	12.9	12.9	5.5	-	OFAF000H16	170M1311	JJS-20	3×1.5	14	217
017A-3	R2	17.0	17.0	7.5	-	OFAF000H25	170M1313	JJS-25	3×6	10	235
025A-3	R2	25.0	25.0	11.0	-	OFAF000H32	170M1313	JJS-35	3×6	10	412
032A-3	R3	32.0	32.0	15.0	-	OFAF000H40	170M1315	JJS-40	3×10	8	400
038A-3	R3	38.0	38.0	18.5	-	OFAF000H50	170M1315	JJS-50	3×10	8	515
045A-3	R4	45.0	45.0	22.0	-	OFAF000H63	170M1316	JJS-60	3×16	6	526
061A-3	R4	61	61	30	-	OFAF000H80	170M1317	JJS-80	3×25	4	818
072A-3	R5	72	72	37	-	OFAF000H100	170M1318	JJS-90	3×35	3	841
087A-3	R5	87	87	45	-	OFAF000H100	170M1319	JJS-110	3×35	3	1129
105A-3	R6	105	105	55	-	OFAF000H125	170M3015	JJS-150	3×50	1	1215
145A-3	R6	145	145	75	-	OFAF000H160	170M3016	JJS-200	3×95	2/0	1962
169A-3	R7	169	169	90	-	OFAF0H250	170M3017	JJS-225	3×120	3/0	2042

ACS880 -01-...	Frame size	Nominal ratings IEC / UL (NEC)				Fuses ³⁾			Typical power cable		Typical power loss ⁸⁾
		Input current	Output current	Motor power ¹⁾		gG fuse ⁴⁾ (DIN 43620)	aR fuse ²⁾⁴⁾ (DIN 43653)	UL class T ₅ (6)7)	Copper		
				P_n	P_{Ld}				mm ² 9)	AWG/ kcmil ¹⁰⁾	
		I_n	I_2 / I_{Ld}	kW	hp	ABB type	Bussmann type	W			
206A-3	R7	206	206	110	-	OFAF1H315	170M3018	JJS-300	3×150	250 MCM	2816
246A-3	R8	246	246	132	-	OFAF1H355	170M5009	JJS-350	2×(3×70)	300 MCM	3026
293A-3	R8	293	293	160	-	OFAF2H425	170M5010	JJS-400	2×(3×95)	2×3/0	3630
363A-3	R9	363	363	200	-	OFAF2H500	170M5012	JJS-500	2×(3×120)	2×4/0	4688
430A-3	R9	430	430	250	-	OFAF3H630	170M5013	JJS-600	2×(3×150)	2×250 MCM	5797
490A-3*	R9	450	490	250	-	OFAF3H630	170M5013	JJS-600	2×(3×240)	2×500 MCM	5831
$U_n = 3\text{-phase } 480\text{ V, } 500\text{ V}$											
02A1-5	R1	2.1	2.1	0.75	1.0	OFAF000H4	170M1308	JJS-15	3×1.5	14	42
03A0-5	R1	3.0	3.0	1.1	1.5	OFAF000H6	170M1308	JJS-15	3×1.5	14	50
03A4-5	R1	3.4	3.4	1.5	2.0	OFAF000H6	170M1308	JJS-15	3×1.5	14	55
04A8-5	R1	4.8	4.8	2.2	3.0	OFAF000H10	170M1308	JJS-15	3×1.5	14	71
05A2-5	R1	5.2	5.2	3.0	3.0	OFAF000H10	170M1308	JJS-15	3×1.5	14	76
07A6-5	R1	7.6	7.6	4.0	5.0	OFAF000H16	170M1308	JJS-15	3×1.5	14	110
11A0-5	R1	11.0	11.0	5.5	7.5	OFAF000H16	170M1308	JJS-20	3×1.5	14	180
014A-5	R2	14	14	7.5	10	OFAF000H25	170M1313	JJS-25	3×6	12	191
021A-5	R2	21	21	11.0	15	OFAF000H32	170M1313	JJS-35	3×6	10	330
027A-5	R3	27	27	15.0	20	OFAF000H40	170M1315	JJS-40	3×10	8	326
034A-5	R3	34	34	18.5	25	OFAF000H50	170M1315	JJS-50	3×10	8	454
040A-5	R4	40	40	22.0	30	OFAF000H63	170M1316	JJS-60	3×16	6	424
052A-5	R4	52	52	30	40	OFAF000H80	170M1317	JJS-80	3×25	4	600
065A-5	R5	65	65	37	50	OFAF000H100	170M1318	JJS-90	3×35	4	715
077A-5	R5	77	77	45	60	OFAF000H100	170M1319	JJS-110	3×35	3	916
096A-5	R6	96	96	55	75	OFAF000H125	170M3015	JJS-150	3×50	1/0	1157
124A-5	R6	124	124	75	100	OFAF000H160	170M3016	JJS-200	3×95	2/0	1673
156A-5	R7	156	156	90	125	OFAF0H250	170M3017	JJS-225	3×120	3/0	1840
180A-5	R7	180	180	110	150	OFAF1H315	170M3018	JJS-300	3×150	4/0	2281
240A-5	R8	240	240	132	200	OFAF1H355	170M5008	JJS-350	2×(3×70)	2×1/0 or 350 MCM	2912
260A-5	R8	260	260	160	200	OFAF2H400	170M5009	JJS-400	2×(3×70)	2×2/0	3325
302A-5	R9	302	302	200	250	OFAF2H500	170M5011	JJS-400	2×(3×95)	2×3/0	3663
361A-5	R9	361	361	200	300	OFAF3H630	170M5012	JJS-500	2×(3×120)	2×4/0	4781
414A-5	R9	414	414	250	350	OFAF3H630	170M5013	JJS-600	2×(3×150)	2×300 MCM	5672
477A-5*	R9	450	477	250	350	OFAF3H630	170M5013	JJS-600	2×(3×240)	2×500 MCM	5598
$U_n = 3\text{-phase } 575\text{ V}$											
07A4-7	R3	7.0	7.0	-	5.0	-	-	JJS-15	-	14	101
09A9-7	R3	9.4	9.4	-	7.5	-	-	JJS-20	-	14	128
14A3-7	R3	13.6	13.6	-	10	-	-	JJS-30	-	12	189
019A-7	R3	18	18	-	15	-	-	JJS-40	-	10	271
023A-7	R3	22	22	-	20	-	-	JJS-50	-	10	338
027A-7	R3	27	27	-	25	-	-	JJS-50	-	8	426
035A-7	R5	41	41	-	40	-	-	JJS-60	-	6	416
042A-7	R5	52	52	-	50	-	-	JJS-80	-	6	524
049A-7	R5	52	52	-	50	-	-	JJS-80	-	6	650
061A-7	R6	62	62	-	60	-	-	JJS-110	-	4	852
084A-7	R6	77	77	-	75	-	-	JJS-150	-	3	1303
098A-7	R7	99	99	-	100	-	-	JJS-150	-	1/0	1416
119A-7	R7	125	125	-	125	-	-	JJS-200	-	2/0	1881
142A-7	R8	144	144	-	150	-	-	JJS-250	-	3/0	1970
174A-7	R8	180	180	-	200	-	-	JJS-300	-	4/0	2670
210A-7	R9	242	242	-	250	-	-	JJS-400	-	350 MCM	2903
271A-7	R9	271	271	-	250	-	-	JJS-400	-	500 MCM	4182
$U_n = 3\text{-phase } 690\text{ V}$											
07A4-7	R3	7.4	7.4	5.5	-	OFAA000GG16	170M1309	-	3×1.5	-	101
09A9-7	R3	9.9	9.9	7.5	-	OFAA000GG20	170M1310	-	3×1.5	-	128
14A3-7	R3	14.3	14.3	11	-	OFAA000GG25	170M1312	-	3×2.5	-	189
019A-7	R3	19	19	15	-	OFAA000GG35	170M1313	-	3×4	-	271
023A-7	R3	23	23	18.5	-	OFAA000GG50	170M1314	-	3×6	-	338
027A-7	R3	27	27	22	-	OFAA000GG50	170M1314	-	3×10	-	426
035A-7	R5	35	35	30	-	OFAA000GG63	170M1315	-	3×10	-	416
042A-7	R5	42	42	37	-	OFAA000GG80	170M1316	-	3×16	-	524
049A-7	R5	49	49	45	-	OFAA000GG80	170M1316	-	3×16	-	650

ACS880 -01-...	Frame size	Nominal ratings IEC / UL (NEC)				Fuses ³⁾			Typical power cable		Typical power loss ⁸⁾
		Input current	Output current	Motor power ¹⁾		gG fuse ⁴⁾ (DIN 43620)	aR fuse ²⁾⁴⁾ (DIN 43653)	UL class T ⁵⁾⁶⁾⁷⁾	Copper		
				P_n	P_{Ld}				mm ² ⁹⁾	AWG/ kcmil ¹⁰⁾	
		I_L	I_2 / I_{Ld}	kW	hp	ABB type	Bussmann type	W			
061A-7	R6	61	61	55	-	OFAA0GG100	170M1318	-	3×25	-	852
084A-7	R6	84	84	75	-	OFAA1GG160	170M1319	-	3×35	-	1303
098A-7	R7	98	98	90	-	OFAA1GG160	170M3015	-	3×50	-	1416
119A-7	R7	119	119	110	-	OFAA1GG200	170M3015	-	3×70	-	1881
142A-7	R8	142	142	132	-	OFAA1GG250	170M3016	-	3×95	-	1970
174A-7	R8	174	174	160	-	OFAA2GG315	170M3017	-	3×120	-	2670
210A-7	R9	210	210	200	-	OFAA3GG400	170M5008	-	3×185	-	2903
271A-7	R9	271	271	250	-	OFAA3GG400	170M5009	-	3×240	-	4182

³⁾Marine type-approved (+C132) and high-speed (+N7500) drives not available at the time of publication. For availability, contact ABB.

Terminal data

Frame size	Cable entries		L1, L2, L3, T1/U, T2/V, T3/W					Grounding terminals			
	pcs per cable type	Max. cable diameter*	Wire size		Tightening torque		Max. wire size		Tightening torque		
			mm	in	mm ²	kcmil/AWG	N-m	lbf-ft	mm ²	AWG	N-m
R1	1	17	0.67	0.75...6	14...10	0.6	0.44	25	4	1.8	1.3
R2	1	17	0.67	0.75...6	14...10	0.6	0.44	25	4	1.8	1.3
R3	1	21	0.83	0.5...16	20...6	1.7	1.25	25	4	1.8	1.3
R4	1	24	0.94	0.5...35	20...2	3.3	2.4	25	4	2.9	2.1
R5	1	32	1.26	6...70	6...1/0	15	11.0	35	2	2.9	2.1
R6	1	45	1.77	25...150	4...300 MCM	30	22.1	185	350 MCM	9.8	7.2
R7	1	54	2.13	95...240 (25...150**)	3/0...400 MCM (4...300 MCM**)	40 (30**)	29.5 (22.1**)	185	350 MCM	9.8	7.2
R8	2	45	1.77	2×(50...150)	2×(1/0...300 MCM)	40	29.5	2×185	2×350 MCM	9.8	7.2
R9	2	54	2.13	2×(95...240)	2×(3/0...500 MCM)	70	51.6	2×185	2×350 MCM	9.8	7.2

Frame size	Cable entries		R-, R+/UDC+ and UDC- terminals				
	pcs	Max. cable diameter*	Wire size		Tightening torque		
			mm	in	mm ²	kcmil/AWG	N-m
R1	1	17	0.67	0.75...6	14...10	0.6	0.44
R2	1	17	0.67	0.75...6	14...10	0.6	0.44
R3	1	17	0.67	0.5...16	20...6	1.7	1.25
R4	1	24	0.94	0.5...35	20...2	3.3	2.4
R5	1	32	1.26	6...70	6...1/0	15	11.0
R6	1	35	1.38	25...95	4...3/0	20	14.8
R7	1	43	1.69	25...150	4...300 MCM	30	22.1
R8	2	45	1.77	2 × (50...150)	2 × (1/0...300 MCM)	40	29.5
R9	2	54	2.13	2 × (95...240)	2 × (3/0...500 MCM)	70	51.6

* maximum cable diameter accepted. Cable clamp connector inside diameter: **Frames R1, R2:** 3/4" (19.05 mm), **Frame R3:** 1" (25.4 mm).

** 525...690 V drives

Notes:

- The minimum specified wire size does not necessarily have sufficient current carrying capacity at maximum load.
- For IEC installations using mm² cable, the terminals do not accept a conductor that is one size larger than the recommended wire size. For NEC installations using AWG cable, this applies only to the R2 frame drive.
- For frames **R1...R7**: The maximum number of conductors per terminal is 1. For frames **R8 and R9**: The maximum number of conductors per terminal is 2.

Dimensions, weights and free space requirements

Frame size	Weights				IP21								IP55					
	IP21 (UL Type 1)		IP55 (UL Type 12)		Height with cable box		Height without cable box (option +P940)		Width with cable box		Depth with cable box		Height with cable box ¹⁾		Width ¹⁾		Depth	
	kg	lb	kg	lb	mm	in.	mm	in.	mm	in.	mm	in.	mm	in.	mm	in.	mm	in.
R1	7.0	15	8.1	18	409	16.11	376	14.80	155	6.10	226	8.89	450	17.72	162	6.38	292	11.50
R2	8.4	19	9.5	21	409	16.11	376	14.80	155	6.10	226	8.89	450	17.72	162	6.38	292	11.50
R3	10.8	24	12.0	26	475	18.71	436	17.17	173	6.81	261	10.28	525	20.70	180	7.09	327	12.87
R4	18.6	41	19.1	42	580	22.85	563	22.17	203	7.99	274	10.79	580	22.85	203	7.99	344	13.53
R5	23	50	23.4	52	732	28.80	653	25.70	203	7.99	274	10.77	732	28.80	203	7.99	344	13.53
R6	42.2	93	42.9	95	727	28.60	593	22.35	252	9.92	357	14.10	727	28.60	252	9.92	421	16.59
R7	53.0	117	54.0	119	880	34.66	645	25.39	284	11.18	365	14.35	880	34.66	284	11.18	423	16.65
R8	68.0	150	74.0	163	965	38.01	724	28.50	300	11.81	386	15.21	966	38.01	300	11.81	452	17.78
R9	95.0	209	102.0	225	955	37.59	723	28.47	380	14.96	413	16.26	955	37.59	380	14.96	477	18.78
R9*	98.0	216	108.0	238	955	37.59	723	28.47	380	14.96	413	16.26	955	37.59	380	14.96	517	20.35

*Drive types 490A-3 and 477A-5.

1) Hood increases drive height and width. For more information, refer to the hardware manual.

200 mm (7.9 in) free space is required at top of the drive.

300 mm (11.8 in) free space (when measured from the drive base without the cable box) is required at bottom of the drive.

Ambient conditions

Installation altitude	0 ... 4000 m (0 ... 13123 ft) above sea level. The output current must be derated at altitudes above 1000 m (3281 ft). The derating is 1% for each 100 m (328 ft) above 1000 m (3281 ft). TN (grounded) and IT (ungrounded) systems. Installing on 525...690 V corner-grounded or midpoint-grounded delta systems is not allowed.
Surrounding air temperature	<u>Operation:</u> -15 ... +55 °C (5 ... 131 °F). Frost is not permitted. The rated output current must be derated by 1% for each 1 °C (1.8 °F) over 40 °C (104 °F) for IP21 (UL Type 1) drives and for IP55 (UL Type 12) frames R1...R7 and R9 (for frame R8, refer to the hardware manual). <u>Storage (in the package):</u> -40 to +70 °C (-40 to +158 °F).

Safe torque off (STO)

The drive has a Safe torque off function (STO) in accordance with IEC/EN 61800-5-2. It can be used, for example, as the final actuator device of safety circuits that stop the drive in case of danger (such as an emergency stop circuit).

When activated, the STO function disables the control voltage of the power semiconductors of the drive output stage, thus preventing the drive from generating the torque required to rotate the motor. The control program generates an indication as defined by parameter 31.22. If the motor is running when Safe torque off is activated, it coasts to a stop. Closing the activation switch deactivates the STO. Any faults generated must be reset before restarting.

The STO function has a redundant architecture, that is, both channels must be used in the safety function implementation. The safety data given in this manual is calculated for redundant use, and does not apply if both channels are not used.



WARNING! The STO function does not disconnect the voltage from the main and auxiliary circuits of the drive.

Notes:

- If stopping by coasting is not acceptable, stop the drive and machinery using the appropriate stop mode before activating the STO.
- The STO function overrides all other functions of the drive.

Wiring

The safety contacts must open/close within 200 ms of each other.

Double-shielded twisted-pair cable is recommended for the connection. The maximum length of the cabling between the switch and the drive control unit is 300 m (1000 ft). Ground the shield of the cable at the control unit only.

Validation

To ensure the safe operation of a safety function, a validation test is required. The test must be carried out by a competent person with adequate expertise and knowledge of the safety function. The test procedures and report must be documented and signed by this person. Validation instructions of the STO function can be found in the drive hardware manual.

Technical data

- Minimum voltage at IN1 and IN2 to be interpreted as "1": 17 V DC
- STO reaction time (shortest detectable break): 1 ms
- STO response time: 2 ms (typical), 5 ms (maximum)
- Fault detection time: Channels in different states for longer than 200ms
- Fault reaction time: Fault detection time + 10ms
- STO fault indication (parameter 31.22) delay: < 500 ms
- STO warning indication (parameter 31.22) delay: < 1000 ms
- Safety integrity level (EN 62061): SIL 3
- Performance level (EN ISO 13849-1): PL e

The drive STO is a type B safety component as defined in IEC 61508-2.

For the full safety data, exact failure rates and failure modes of the STO function, refer to the drive hardware manual

Markings

The applicable markings are shown on the type designation label of the drive.



Related documents

Document	Code (English)
ACS880-01 hardware manual	3AUA0000078093
ACS880 primary control program firmware manual	3AUA0000085967
ACS-AP-I, -S, -W and ACH-AP-H, -W Assistant control panels user's manual	3AUA0000085685
Drive composer PC tool user's manual	3AUA0000094606
Converter module capacitor reforming instructions	3BFE64059629
Common mode filter kit for ACS880-01 frame R6 (option +E208) installation instructions	3AXD50000015178
Common mode filter kit for ACS880-01 frame R7, and for ACS880-11, ACS880-31, ACH580-31 and ACQ580-31 frame R8 installation instructions	3AXD50000015179
Common mode filter kit for ACS880-01 frame R8 (option +E208) installation instructions	3AXD50000015180
Common mode filter kit for ACS880-01 drives (frame R9, option +E208) installation instructions	3AXD50000015201
Input side common mode filter kit for ACS880-01-490A-3, -477A-5 and -453A-4 (option +E202) and for ACS580-01, ACH580-01 and ACQ580-01 -490A-4 and -477A-4 installation instruction	3AXD50001192297
ACS880-01..., ACS880-04..., ACS880-11... ACS880-31..., ACS880-14... and ACS880-34... +C132 marine type-approved drives supplement	3AXD50000010521

Declarations of Conformity



[Link to Declaration of conformity according to EU Machinery Directive 2006/42/EU \(3AXD10000099646\)](#)



[Link to Declaration of China RoHS II conformity \(3AXD10001497397\)](#)



[Link to Declaration of conformity according to UK Supply of Machinery \(Safety\) Regulations 2008 \(3AXD10001329538\)](#)